

# ROCKNROLLER®

## MULTI-CART®

Congratulations on your purchase from RocknRoller Multi-Cart, the most acclaimed and innovative transforming utility carts available. Although very easy to use, RocknRoller Multi-Cart's patented design operates differently than typical carts or dollies. To ensure maximum performance from your RocknRoller Multi-Cart, we recommend reading this instruction and assembly sheet thoroughly. U.S. Patent #'s: 5,228,716; 5,476,282; 6,966,574; 7,437,801; 7,490,847 & Pats. Pend.

**LIMITED WARRANTY:** RocknRoller Multi-Carts carry a one year limited warranty against defective material or workmanship on basic frame and components. Casters and wheels carry a 60 day warranty against defects. As with any equipment, normal maintenance is required. Caution should be used when moving any load with Multi-Carts or any other dolly.

R6G Model Specifications		Your RocknRoller Multi-Cart shipping box should contain a frame and the following parts:		Recommended Tools For Assembly	
Length (Compact)	28"	2 x	1/2" flat washers	Channel Lock Pliers (not included)	
Length (Extended)	42.5"	2 x	1/2" lock nuts		
Width (Frame Bed)	12.5"	1 x	1" (25 mm) square plastic endplugs		
Width (Rear Wheels)	18"	1 x	3/4" (20 mm) square plastic endplugs		
Height (Folded)	9.5"	2 x	1/8" x 1 1/4" cotter pins		
Height (Unfolded)	33.25"	2 x	20 mm flat washer		
Front Casters	5" x 2"	2 x	8" x 3" (200mm x 75mm) rear wheels		
Rear Wheels	8" x 3"	2 x	5" x 2" (125mm x 51mm) stem casters		
Weight	22 lbs.	1 x	Flat Wrench		
Load Capacity	500 lbs.	1 x	Assembly/instruction sheet		
		2 x	570 mm Non-skid Tape		

## Assembly Instructions

**Caution:** Be careful to not pinch or strike fingers during assembly. Be careful of metal burrs inside tubing.

### 1. Installing Rear Wheels

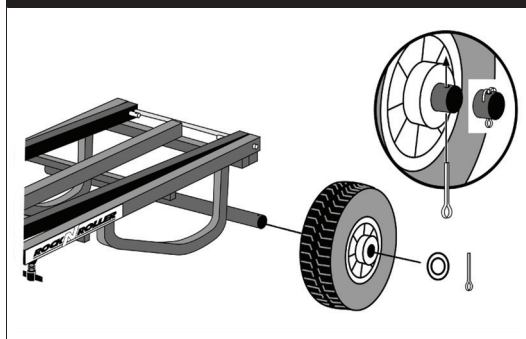

Gently slide wheel over axle as shown. Do not force wheels onto axle. It is recommended to lubricate axles with light grease before installing. Install cotter pins and bend ends outward.

### 2. Installing Front Swivel Casters

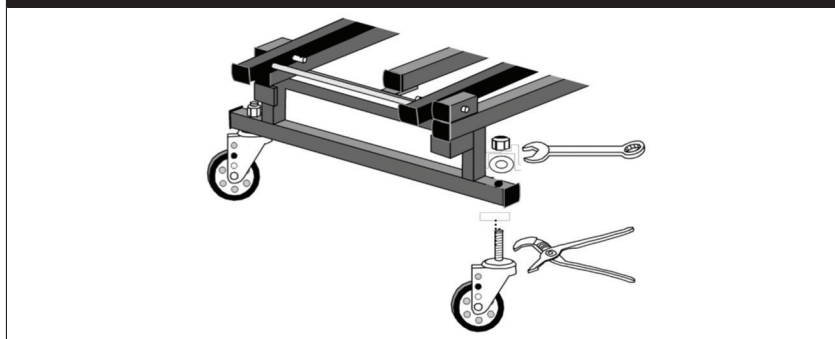

Attach front swivel casters as shown. While tightening lock nuts, grip bearing cap with channel lock pliers or pipe wrench to prevent threaded stem from turning. Tighten lock nuts firmly, but not excessively tight. Check lock nut tightness on caster stems periodically.



Customer Service & Technical Support  
ACE PRODUCTS GROUP

3920 Cypress Drive, Suite B Petaluma, CA 94954 • 800-950-1095 • 707-765-1500 • www.rocknrollercart.com • info@aceproducts.com

# Operating your RockNRoller® Multi-Cart®

## Multi-Carts instantly transform into any of 8 different configurations

**Caution:** When loading equipment on a hill or incline, set brake. (Block wheels if load is very heavy). Caution should be used when moving any load with Multi-Carts or any other dolly. Over rough terrain it is recommended to push cart with the large wheels forward.



### Extending Frame



Loosen wingbolts 1/4 turn. Step on rear axle and push in extension stop button. Pull up on frame as shown until stop button engages. Retighten wingbolts.

### Raising Foldable Sides



Firmly press down on release cable while raising other end of foldable side as shown.

Repeat with other side.

- SHORT FURNITURE DOLLY:** Place cart on all four wheels with sides folded down as shown. When using Multi-Cart in extended 4-wheel dolly configuration, distribute load evenly over frame bed when possible, placing the heaviest items over the large rear wheels to make rolling easier.
- LONG NOSE LUGGAGE CART:** Extend cart into 4-wheel hi-stacker mode. Set on one end as shown, pull top release cable and lower top foldable side.
- STORAGE-TRANSPORT:** With sides upright, place cart on end, loosen wingbolts under frame 1/4 turn, push in extension stop button, and push down to compact cart to minimum length. Retighten wingbolts. Place cart on all 4 wheels. FOLD HANDLES IN THIS ORDER: 1st, push down release cable over large wheels with one hand and fold down side with the other hand. 2nd, fold side over front swivel casters in the same manner. Cart will not fold down correctly unless done in this order. Stand cart on end to store or place upside down to ride in vehicles or on airport conveyor belts.
- SHORT PLATFORM CART:** Firmly push down on release cable located over swivel casters with one hand while raising the foldable side with the other hand until side locks into place in upright position.
- SHORT HI-STACKER:** Raise both sides as previously described.
- LONG PLATFORM CART:** Take short hi-stacker configuration and set on 2 large wheels (upright). Loosen 2 wingbolts 1/4 turn and pull frame upward until button engages. Retighten wingbolts and set cart back on all 4 wheels.
- LONG HI-STACKER:** Raise folded handle of long platform cart.
- LONG PLATFORM CART:** From long hi-stacker configuration, fold down side over large wheels first, then fold down side over swivel casters.

## RockNRoller® Multi-Cart® R6G Accessories

### Removable Shelves



### Solid Deck



### Cable/headphone hanger



### Laptop Shelf



### Flex Straps



**ROCKNROLLER®**  
MULTI-CART®

Customer Service & Technical Support

ACE PRODUCTS GROUP

3920 Cypress Drive, Suite B Petaluma, CA 94954 • 800-950-1095 • 707-765-1500 • www.rocknrollercart.com • info@aceproducts.com