

JTS®

LIGHTER
SMALLER

MORE POWERFUL
GUITAR / ACCORDING / WINDS / BRASS

FC CE1856 !  

59508-033-04



MINIATURE *MUSIC*
INSTRUMENTS

WIRELESS SYSTEM

Instruction Manual

Thank you for choosing the JTS wireless system. In order to obtain the best efficiency from the system, you are recommended to read this instruction manual carefully.

1. Important Caution	01
2. Features	01
3. Specification	02
3-1 Receiver// UR-816D (DB)	02
3-2 Miniature Transmitter// UT-16GT/UT-16GTP	02
4. Part Identification & Accessories	03
4-1 Receiver// UR-816D (DB)	03
4-2 Miniature Transmitter// UT-16GT/UT-16GTP	04
4-3 Accessories	05
5. Preparing Procedures & Basic Operation	06
5-1 Receiver	06
5-2 Battery Insertion of The Transmitter	07
5-3 Install The Transmitter	08
6. System Operation	11
7. Rack Mounting	12
8. Recommendation	13
9. Important Notice	14

1. Important Caution

- Always make all connections before plugging the unit into an AC power outlet.
- Do not leave the devices in a place with high temperature or high humidity.
- Do not handle the power cord with wet hands!
- Keep the devices away from fire and heat sources.
- This is a general user's manual. To check out standard accessories please find them on the product packing box.

2. Features

UT-16GT/UT-16GTP provides true wireless experience to musicians. Within limited space it delivers uncompromised features.

- Innovative combo design good for guitar, accordion, winds & brass
- UHF PLL 16 channels
- At least 60 meter operation distance
- Tone Key Squelch
- Higher signal to noise ratio
- One AAA 1.5V battery runs for 8 hours

3. Specification

3-1 Receiver// UR-816D (DB)

Frequency Preparation...	PLL Synthesized Control
Carrier Frequency Range	502~960 MHz
S/N Ratio.....	> 105dB
T.H.D.....	<0.6%@1KHz
Display.....	LED
Display Contents.....	Antenna A/B, RF/AF Status
Controls.....	Power On/Off, Channel Selecting, Audio Level
Audio Output Level.....	-12dB
AF Output Impedance...	600Ω
Squelch.....	Pilot Tone, Noise and Mute
Operation Voltage.....	12-18 VDC, 200mA
Output Connector.....	1 Balanced XLR socket 1 Unbalanced Ø6.3mm phone jack
Dimension(m/m).....	816D 210mm (W)* 40mm (H)* 171mm (D) 816DB 210mm (W)* 40mm (H)* 181mm (D)

3-2 Miniature Transmitter// UT-16GT/UT-16GTP

Frequency Preparation....	PLL Synthesized Control
Carrier Frequency Range..	502~960 MHz
RF Outputs.....	Maximum 10mW
Stability.....	±10KHz
Frequency Deviation.....	±48KHz
LED Display.....	Power On/Off, Low battery, Mute
Controls.....	Power On/Off, AF Level, Channel Selecting, Mute
Spurious Emissions.....	<-50 dBC
Audio Frequency Response	40~18,000 Hz
Battery.....	LR03, AAA 1.5V*1

4. Parts Identification & Accessories

4-1 Receiver// UR-816D (DB)

Front panel

- 1 Antenna
- 2 Power On/Off Switch
- 3 Power LED
- 4 Channel selector
- 5 RF indicator
- 6 AF indicator
- 7 Volume control

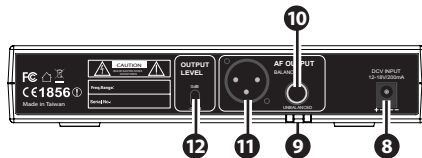
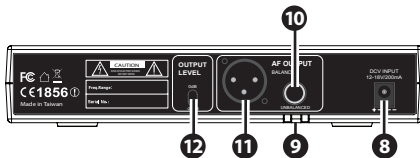
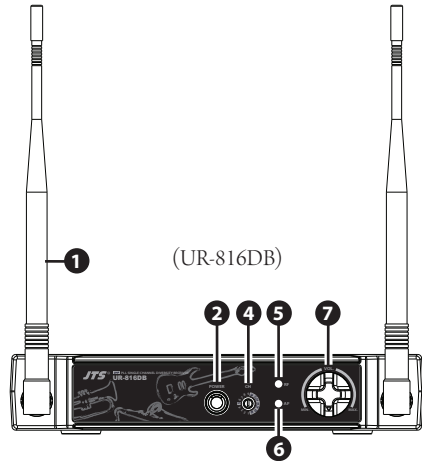
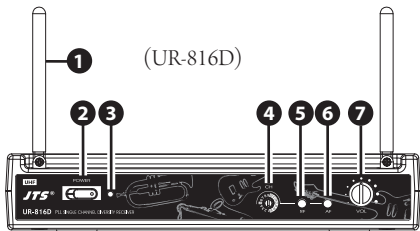

Rear panel

- 8 Power Supply Jack (12-18V/200mA): for connecting the power supply unit.
- 9 Strain Relief: for the connection cable of the power supply unit, which leads the cable around the hook to prevent accidental disconnection of the plug from the jack.
- 10 AF Output (6.3mm jack, unbalanced): for connection to a unbalance input, e.g. of a mixer or amplifier.
- 11 Balanced XLR Output: for connection to the balanced input, e.g. of a mixer or an amplifier.
- 12 Output Level Attenuation(-20dB): to attenuate the balanced XLR output level by -20dB.

4-2 Miniature Transmitter

- ① UT-16GT/UT-16GTP
- ② Power On/Mute/Off switch
- ③ LED indicator for power On/Off, battery status and mute
- ④ Channel selector
- ⑤ Input gain
- ⑥ Antenna
- ⑦ 6.3GT plug: Jack plug
- ⑧ 516GT: Accordion microphone module
508GT: Winds & Brass microphone module
- ⑨ 16GT Adapter
- ⑩ 516 Bracket
- ⑪ 16GT Clip: Winds clip
- ⑫ Battery Lid (Color ID): Orange / White / Silver included
- ⑬ CLP-UT

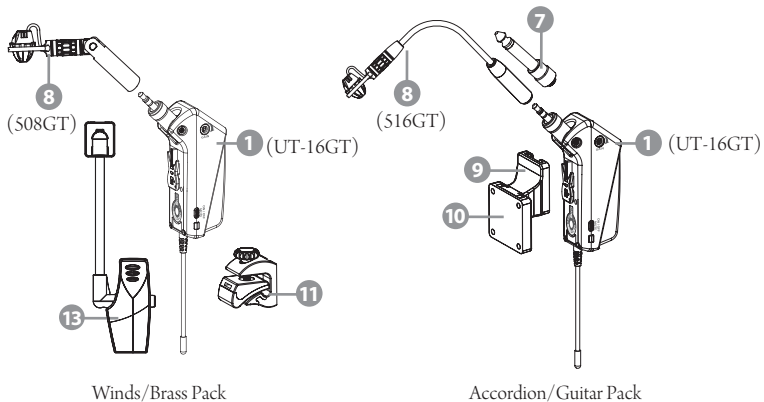
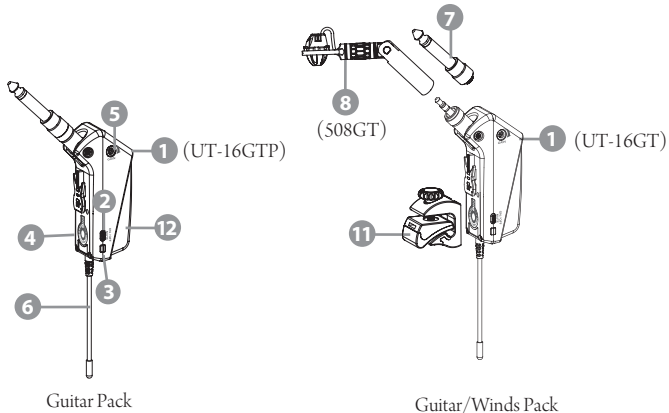

4-3 Accessories

- 14 AC/DC adaptor
 - A Switching Power Supply (100~240V, 50~60Hz)
 - B Linear Power Supply (220V, 50Hz) Option
 - C Linear Power Supply (220V, 60Hz) Option
- 15 AF output cable
- 16 Screwdriver
- 17 Sucker Holder
- 18 DR-900 dual rack adaptor Option
- 19 RP-900 panel cover Option
- 20 Adhesive tape *2
- 21 Windscreen

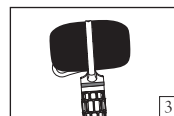
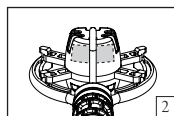
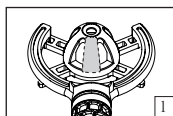
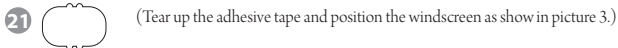
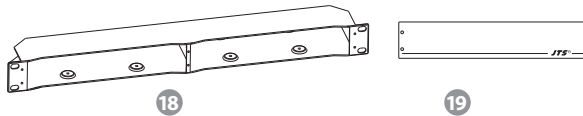
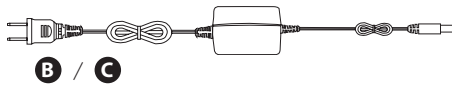
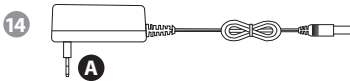

5. Preparing Procedures & Basic Operation

5-1 Receiver

(1) Connect to the subsequent unit (e.g. mixer, or amplifier)

Connect one end of a proper AF cable to the AF Output or Balanced XLR Output socket, then plug another end to the "MIC IN" input socket of a mixer or an amplifier (Step 1)

(2) Connect the power supply unit

Plug in one end of AC/DC adaptor cable to Power Supply Jack in the rear panel of receiver, and plug another end into an AC outlet (Step 2)

Caution

To prevent accidental disconnection of the plug from the jack, lead the cable around the hook of the strain relief.

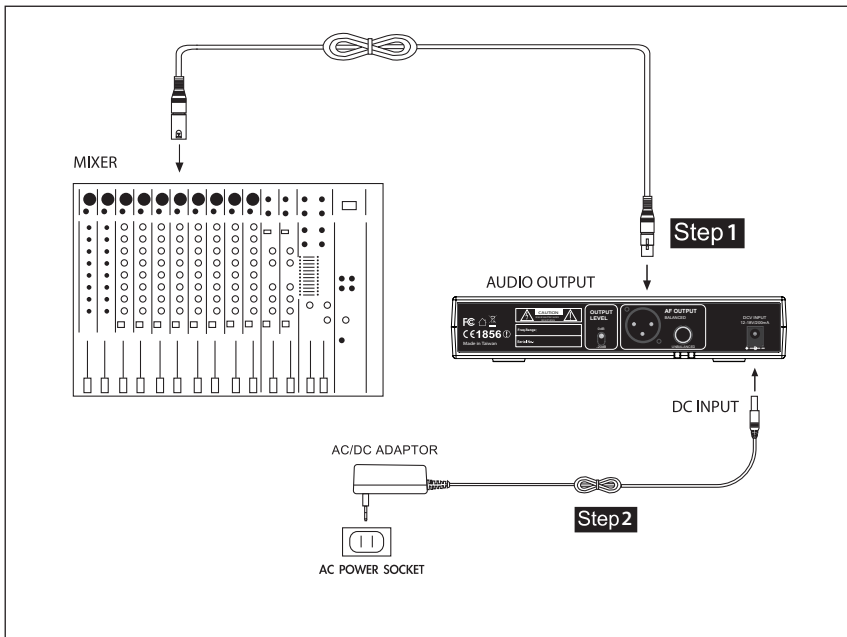

5-2 Battery Insertion Of The Transmitter

- (1) Press Down the battery lid **12** and slide it out.
- (2) Insert or replace with a new battery according to the polarity indication.
- (3) Switch the ON/MUTE/OFF **2** switch to ON. If the battery is in good condition the LED indicator **3** will light in Green constantly. As soon as the battery goes below a preset level the LED indicator **3** will turn to Red constantly. Then the remaining battery life will last for 30 minutes only.
- (4) Slide and push back the battery lid.

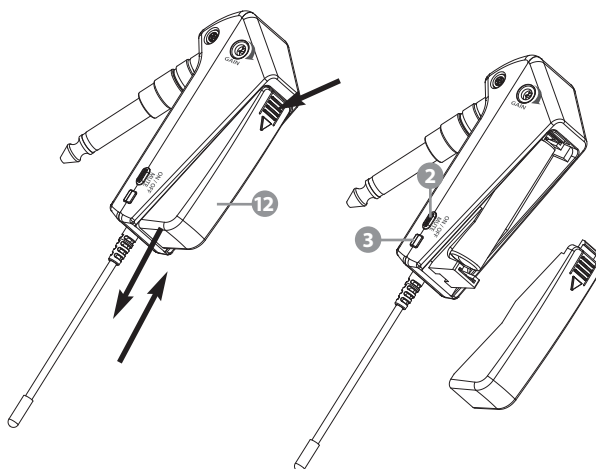

5-3 Install the transmitter

(1) Use the UT-16GT+6.3GT plug for guitar application

1. Insert the plug to the transmitter and turn it to the end.
2. Plug the transmitter into the instrument to be used.
3. Push down the transmitter towards the instrument. The step positioning mechanism will hold the transmitter firmly on the instrument.
4. For traditional Gibson style end-mount input a sucker holder ⑰ is provided to prevent swiveling of the transmitter.

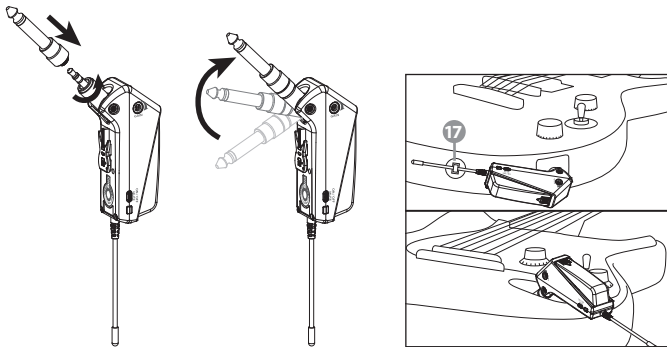

(2) Use the UT-16GTP for guitar application

1. Plug the transmitter into the instrument to be used.
2. Push down the transmitter towards the instrument. The step positioning mechanism will hold the transmitter firmly on the instrument.
3. For traditional Gibson style end-mount input a sucker holder ⑰ is provided to prevent swiveling of the transmitter.

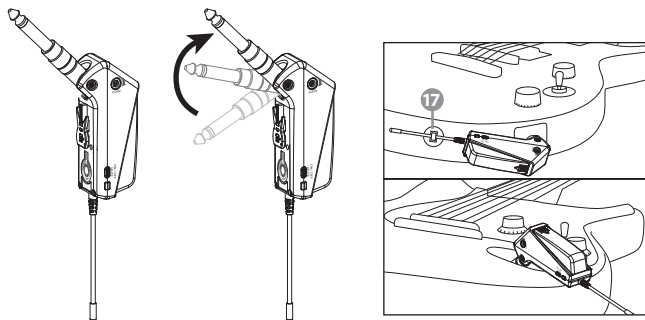

(2) Use the 516GT/508GT microphone module for accordion/winds/brass application

- ① Insert the 516GT/508GT to the transmitter and turn it to the end.
- ② Slide the 16GT Adapter/16GT CLIP/CLP-UT into the transmitter and push it to the end.
- ③ Fix the 16GT Adapter + 516 Bracket to the accordion by double-sided adhesive tape.
- ④ Fix the 16GT CLIP / CLP-UT to the instrument.
- ⑤ Adjust the 516GT/508GT to a position for desired sound performance.

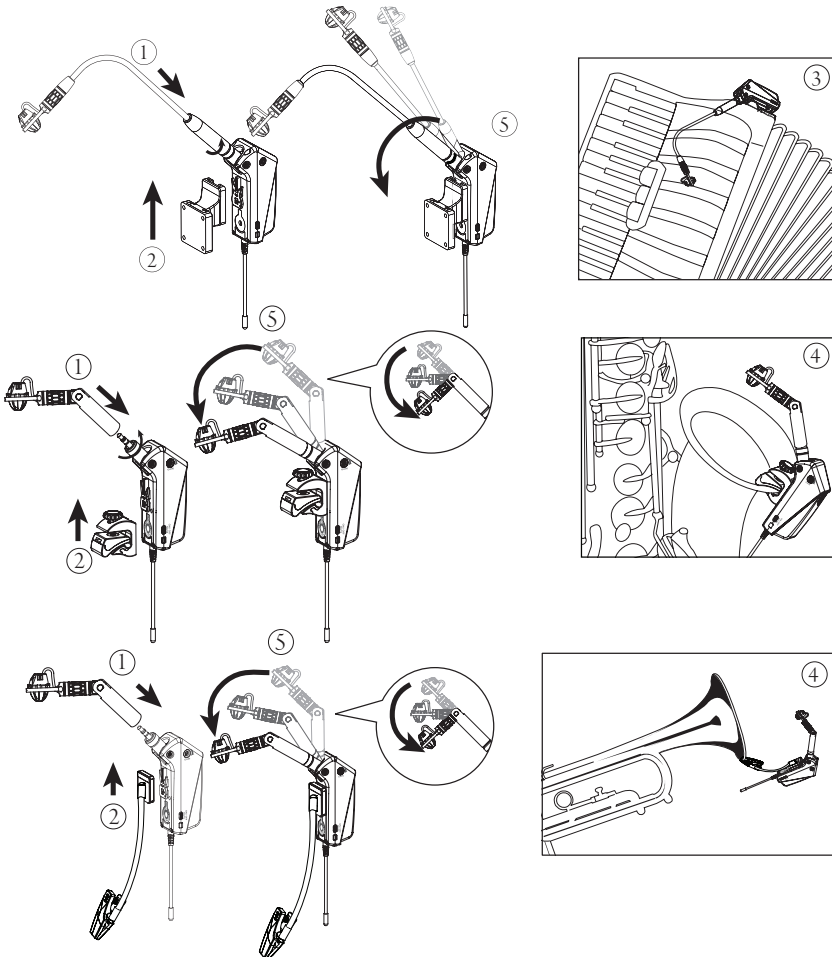

(3) Setting Levels

1. Set a common frequency for both the receiver and transmitter by turning the Channel Selector **4** with supplied screw driver.
2. Turn the input gain control **5** on the transmitter to a position halfway between the left and right stops.
3. Set the ON/MUTE/OFF switch **2** to ON to switch on transmitter.
4. Switch on the receiver and sound system.
5. Turn the volume control on the transmitter to maximum level (clockwise) and play a few notes.
6. If the instrument sounds distorted turn down (count clockwise) the Input Gain **5** to a point where no distortion is heard. If the instrument sounds too low, turn up (clockwise) the Input Gain **5** just before distortion is heard.

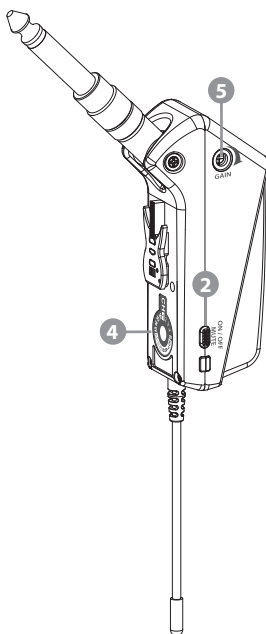

6. System Operation

Be sure to mute the audio signal of a mixer or amplifier before turning on the receiver and transmitter.

(1) Power on

Turn AF level on the receiver completely counter-clockwise to the minimum level, and switch on the receiver. As soon as you turn power **2** of the receiver on, the power LED **3** lights red, meanwhile the RF **5** signal and AF **6** LED light up to indicate the system is ready for operating.

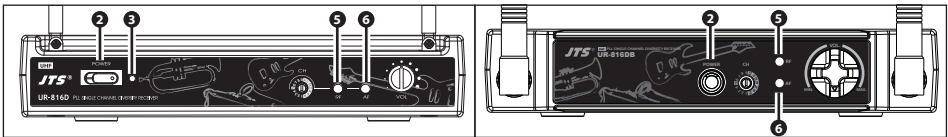

It is always a good idea to keep “open space” between transmitter and receiver, that will improve RF reception.

(2) Selecting channel for the receiver and transmitter

1. Use the supplied screwdriver to select a desired channel for the receiver **4** and transmitters **4**. Both receiver and transmitters are preprogrammed with 16 channels.

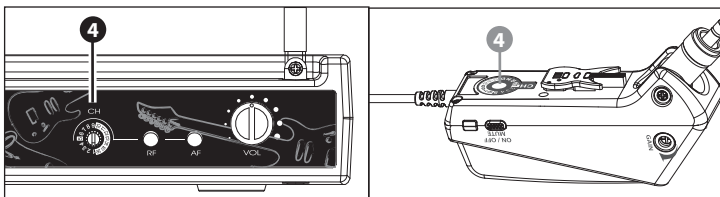

2. Make sure the channel of receiver matches that of the transmitter.
3. When 2 or more system are being used in the same location, they must be set up to use different channels. If existing channel is being interfered, please change to another non-interference channel.

7. Rack Mounting

- (1) Before mount receivers onto DR-900 rack adaptor, please release any cables from the rear of the receiver.
- (2) Turn over receiver and DR-900 rack adaptor simultaneously, there are 4 threaded holes at the bottom of receiver and rack adaptor for inserting screws.
- (3) Single receiver
Insert in a receiver through the front of DR-900 until it is firmly attached to the rack, then screw on a RP-900 to another side of the rack.
- (4) Dual receivers
The same way as above, put one receiver to each rack space.

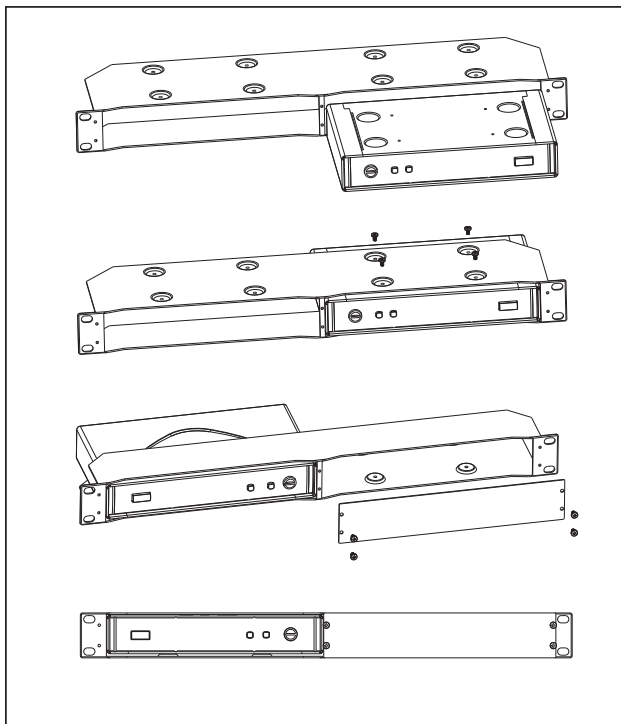

8. Recommendation

- (1) In order to achieve the optimum reception condition and also extend the operating distance, please leave on “open space” between the receiver and transmitter.
- (2) Keep the devices away from the metal objects or any interference sources at least 50 cm.
- (3) To avoid the feed-back effect, don't leave the mic. to aim at the speakers directly.
- (4) Remove batteries from the battery compartment when the transmitter will not be used for a long time.

9. Important Notice

- (1) JTS offers wireless systems in a selection of bands that conform to the different government regulations of specific nations or geographic regions. These regulations help limit radio frequency (RF) interference among different wireless devices and prevent interference with local public communications channels, such as television and emergency broadcasts.
- (2) For information on bands available in your area, consult your local dealer or phone JTS. More information is also available at JTS's website (www.jts.com.tw).
- (3) This Radio apparatus may be capable of operating on some frequencies not authorized in your region. Please contact your national authority to obtain information on authorized frequencies and RF power levels for wireless microphone products.